

**FLUSH STILE**

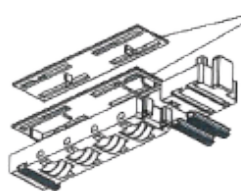
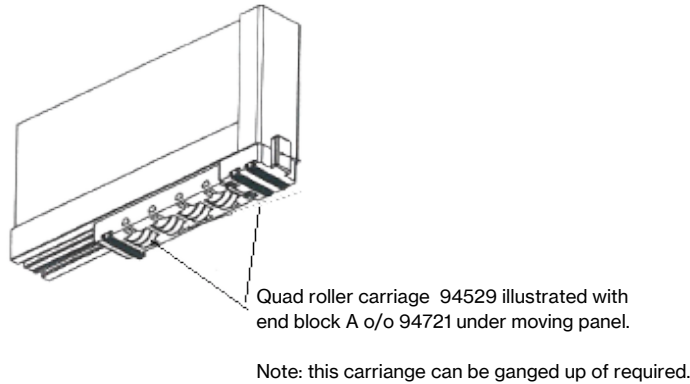
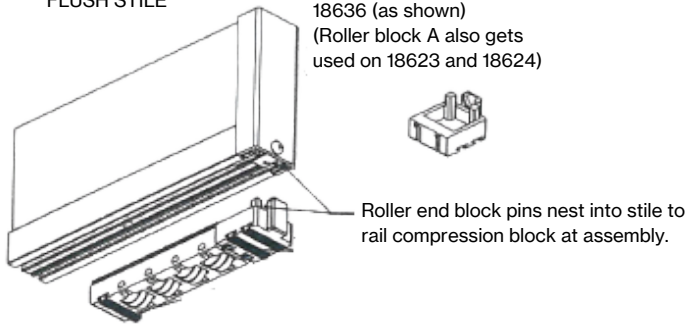

Roller carriage supplied with 1.50mm nylon shims to allow panel height adjustment if required. The standard installment of roller carriage is with one shim (the lower shim with tabs that nests into the roller carrier) Use nylon shims as required.

Apply a small lick of silicone or small joint sealant between shim and roller main carriage plus shim and bottom rail to adhere the roller assembly to hold onto bottom rail while panel is being lowered onto the sill track.

**MEETING STILE**  
(on the inside)

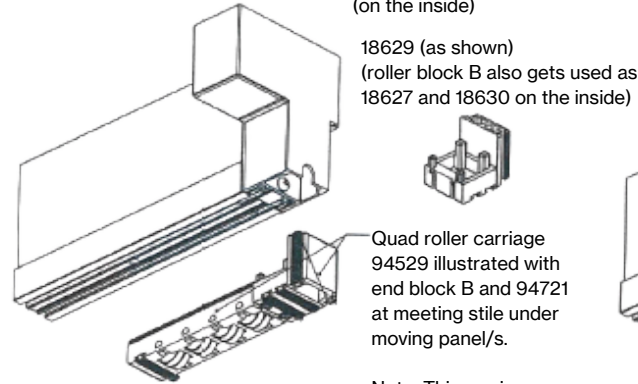

Note: This carriage can be ganged up if required.

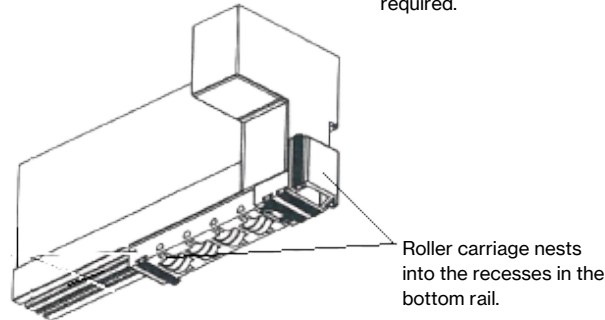

**LOCK STILE**

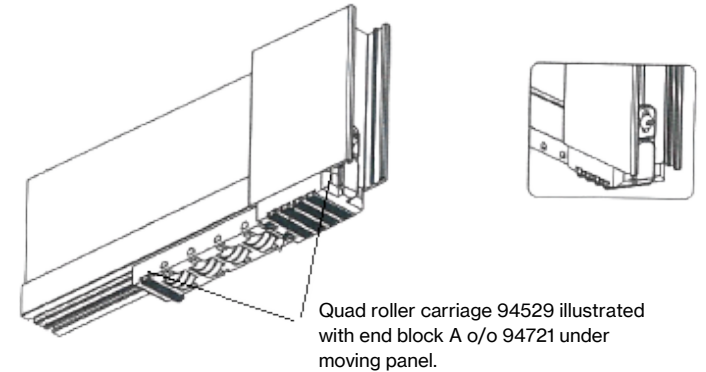
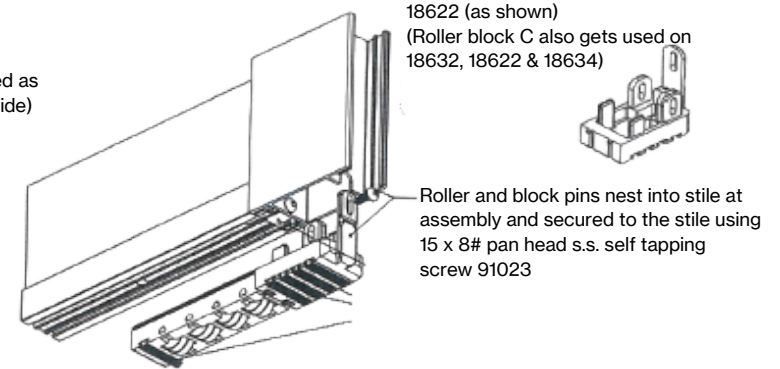

Note: This carriage can be ganged up of required.

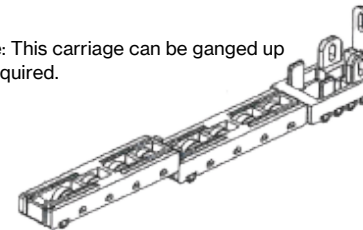

# 758 / 759 Rollers to Stile Guide